

Name (Print) _____
(Last) (First)

**ME 323 – Mechanics of Materials
Examination #2 – Fall 2017
Tuesday, November 14**

Instructions

Circle your instructor's name/class period:

**Gonzalez
11:30**

**Krousgrill
12:30**

**Zhao
2:30**

**Krousgrill
4:30**

This is a closed book/closed notes exam.

Please remember that for you to obtain maximum credit for a problem, you must present your solution clearly. Accordingly,

- coordinate systems must be clearly identified,
- free body diagrams must be shown,
- write down clarifying remarks,
- state your assumptions, etc.

If your solution cannot be followed, it will be assumed that it is in error.

PLEASE DO NOT WRITE ON THE BACK SIDE OF THE EXAM PAPERS.

Do not separate the exam sheets during the exam. Be sure that ALL SHEETS are in the correct sequential order when you submit your completed exam.

Prob. 1 _____

Prob. 2 _____

Prob. 3 _____

Prob. 4 _____

Total _____

Please read the following statement and sign. An unsigned exam will not receive a score.

I have neither given nor received unauthorized assistance during the completion of this exam.

Signature: _____

ME 323 Examination #2

Name _____

November 14, 2017

Instructor _____

PROBLEM NO. 1 – 30 points max.

The cantilever beam AD of the bending stiffness EI is subjected to a concentrated moment M_0 at C. The beam is also supported by a roller at B. Using Castigliano's theorem:

- Determine the reaction force at the roller B.
- Determine the rotation angle of the beam about z axis at the end A.

Ignore the shear energy due to bending. Express your answers in terms of M_0 , E , and I .

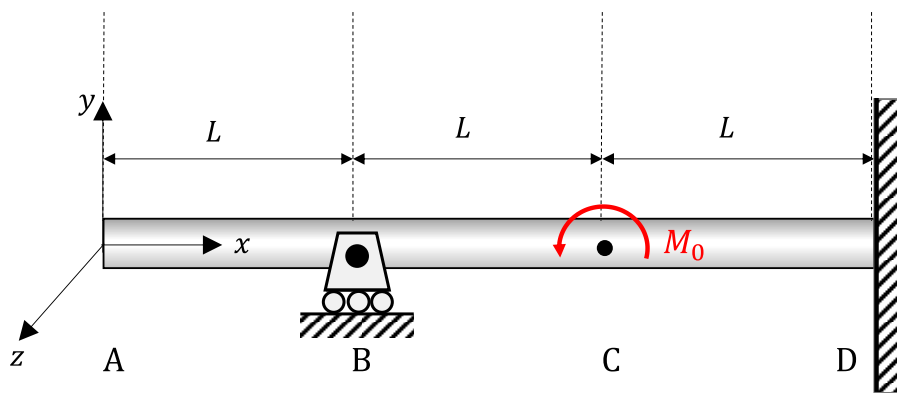

ME 323 Examination #2

Name _____

November 14, 2017

Instructor _____

PROBLEM NO. 1 (continued)

ME 323 Examination #2

Name _____

November 14, 2017

Instructor _____

PROBLEM NO. 1 (continued)

ME 323 Examination #2**Name** _____**November 14, 2017****Instructor** _____**PROBLEM NO. 2 – 25 points max.**

At a point A above the neutral axis of the beam shown in the figure, the state of plane stress can be described by the insert on the right-hand side of the figure. The maximum in-plane shear stress at this point is $\tau_{max} = 13\text{MPa}$, the normal stress in the x -direction is $\sigma_x = 20\text{MPa}$, and normal stress in the y -direction is $\sigma_y = 0\text{MPa}$.

- Determine the magnitude of the shear stress, τ_{xy} , on the x and y faces.
- Determine the sign of the shear stress τ_{xy} . HINT: Determine first the direction of the shear force acting on the cross-section with normal x at point A .
- Draw Mohr's circle corresponding to the state of stress at point A . Clearly indicate the location of the center of the circle, the radius of the circle and point X (which represents the stress state on the x -face) in this drawing.
- Determine the two in-plane principal stresses at this point. Determine the rotation angle of the stress element for each principal stress.
- Show the locations of the principal stresses and of the in-plane maximum shear stress on your Mohr's circle in c) above.

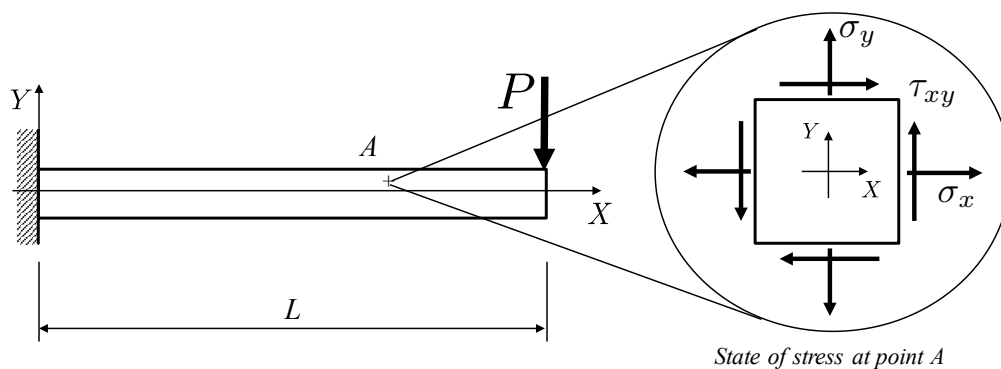

ME 323 Examination #2

Name _____

November 14, 2017

Instructor _____

PROBLEM NO. 2 (continued)

ME 323 Examination #2

Name _____

November 14, 2017

Instructor _____

PROBLEM NO. 2 (continued)

ME 323 Examination #2

Name _____

November 14, 2017

Instructor _____

PROBLEM NO. 3 – 25 points max.

The propped cantilever in the figure is simply supported at end A and fixed at end B . It supports a linearly distributed load of maximum intensity w_0 on the span AB .

- Draw a free body diagram of the structure. Assume the reactions forces act in the direction of positive x and y axes, and the reaction moments act counterclockwise.
- State the equations of equilibrium of the structure and indicate whether it is statically determinate or indeterminate.
- Indicate all the boundary conditions that correspond to this problem.
- Use the second-order integration method (or the fourth-order integration method) to determine an expression for the reaction(s) at the support A . Express the result as a *sole* function of L , w_0 and EI .
- Determine an expression for the deflection of the beam as a *sole* function of L , w_0 and EI .
- Sketch the deflection curve. This sketch does not need to be exact; show enough details to include the displacement and slope boundary conditions and approximate location of the maximum deflection.

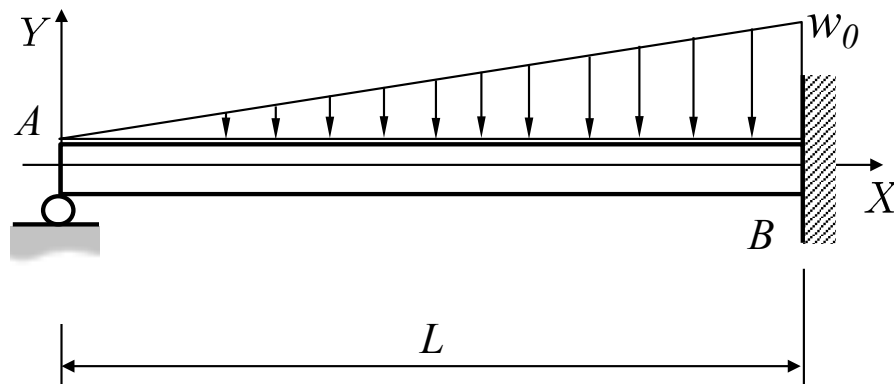

ME 323 Examination #2

Name _____

November 14, 2017

Instructor _____

PROBLEM NO. 3 (continued)

ME 323 Examination #2

Name _____

November 14, 2017

Instructor _____

PROBLEM NO. 3 (continued)

ME 323 Examination #2

Name _____

November 14, 2017

Instructor _____

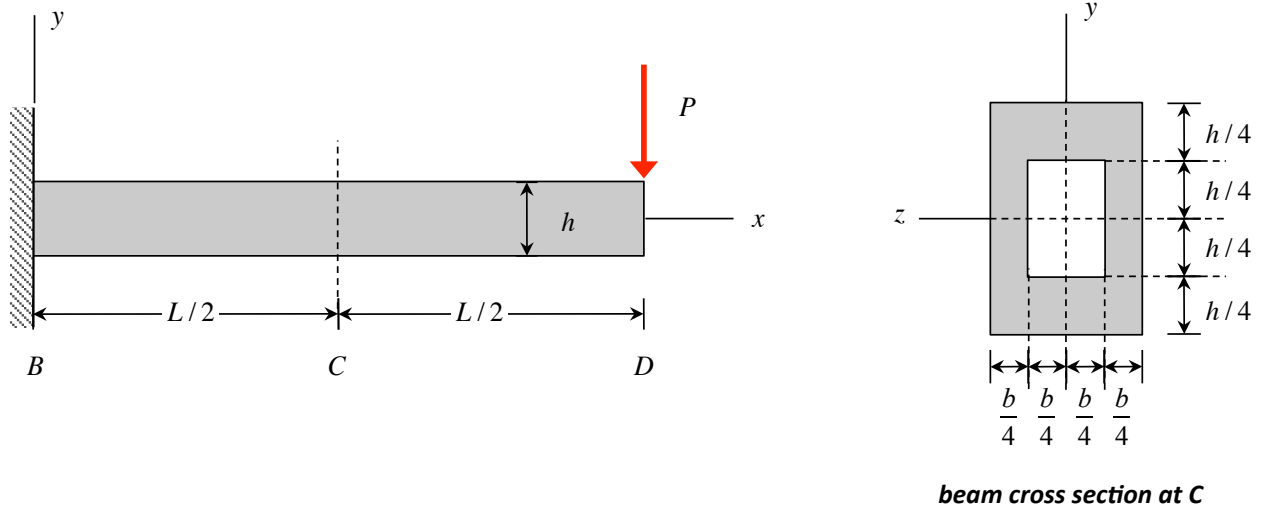
PROBLEM NO. 4 - PART A – 4 points max.

Consider the cantilevered beam above with the concentrated load P at end D. Determine the *shear stress* on the neutral surface of the beam at location C along the beam.

ME 323 Examination #2

Name _____

November 14, 2017

Instructor _____

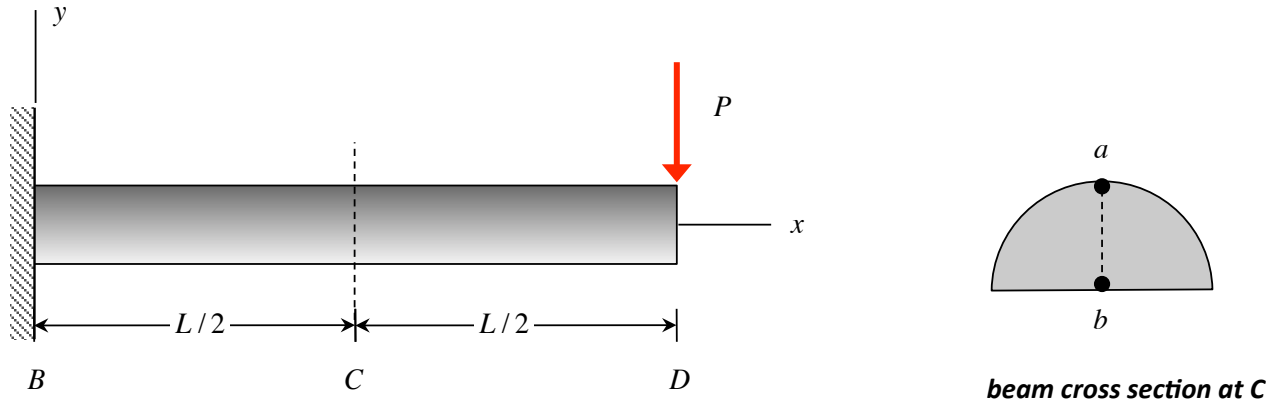
PROBLEM NO. 4 - PART B – 3 points max.

Consider the cantilevered beam above with the concentrated load P at end D. Consider the axial components of stress at points “a” and “b” (σ_a and σ_b , respectively) at location C along the beam. Circle the response below that most accurately describes the relative sizes of the magnitudes of these two stresses:

- a) $|\sigma_a| > |\sigma_b|$
- b) $|\sigma_a| = |\sigma_b|$
- c) $|\sigma_a| < |\sigma_b|$

ME 323 Examination #2

Name _____

November 14, 2017

Instructor _____

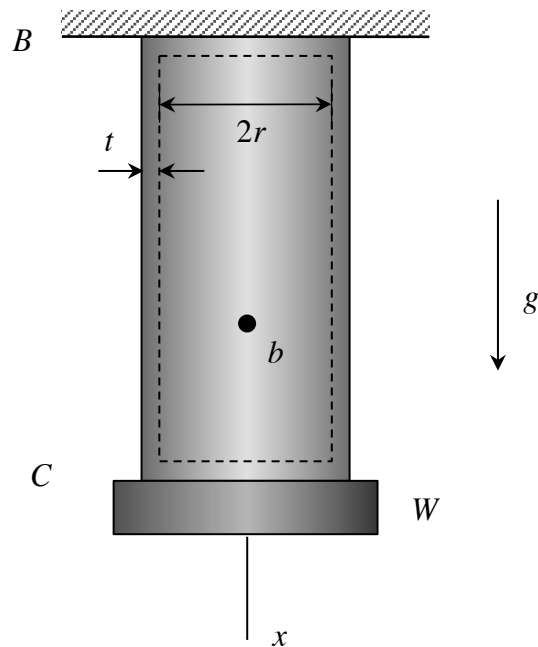
PROBLEM NO. 4 - PART C – 4 points max.

Consider the thin-walled pressure vessel above that contains a gas under a pressure of p . The vessel is attached to a fixed support at B and has a plate of weight W attached to it at end C. Ignore the weight of the vessel. Determine the weight W of the plate for which the *maximum in-plane shear stress* in the vessel at any arbitrary point “b” in the vessel wall is zero.

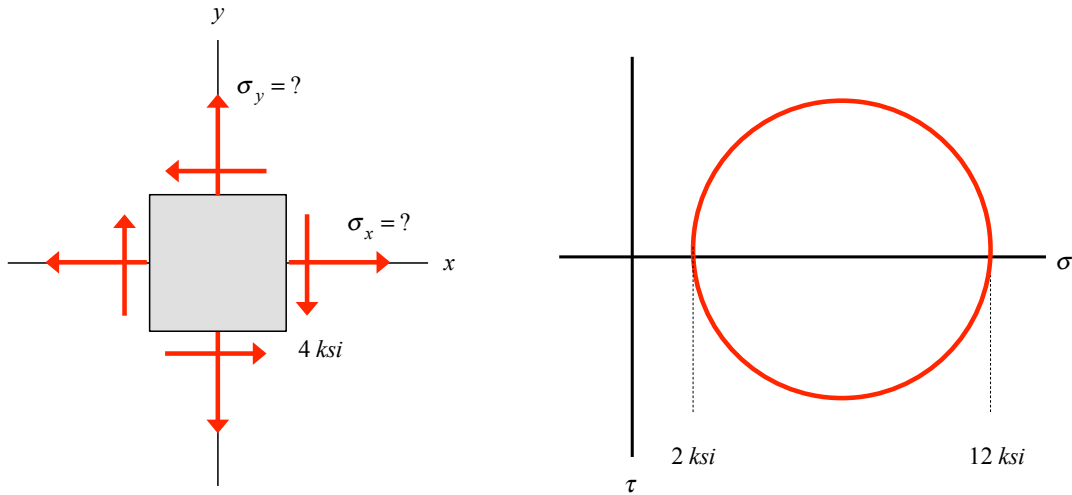
ME 323 Examination #2**Name** _____**November 14, 2017****Instructor** _____**PROBLEM NO. 4 - PART D – 4 points max.**

Consider the state of plane stress shown above left where the two normal components of stress, σ_x and σ_y , are unknown. The Mohr's circle for this state of stress is provided in the figure above right. Determine the two normal components of stress σ_x and σ_y . There may be more than one set of answers; you need only find one set.

ME 323 Examination #2

Name _____

November 14, 2017

Instructor _____

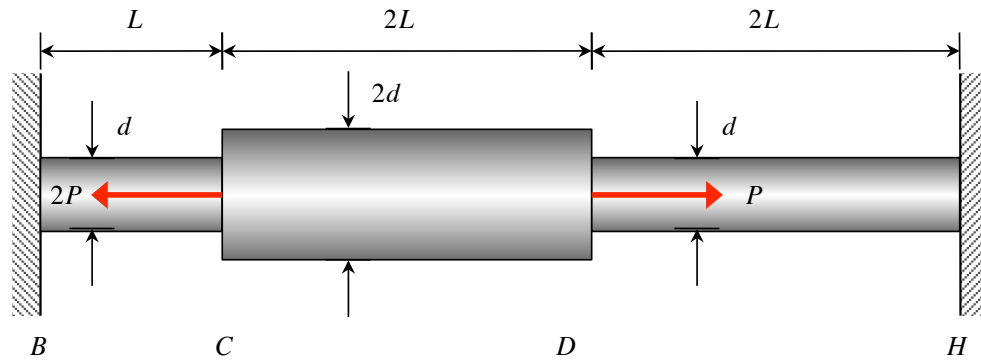
PROBLEM NO. 4 - PART E – 5 points max.

A rod is made up of three circular cross-section components: BC, CD and DH. The material for all components have a Young's modulus of E . Suppose you are to develop a finite element model for the rod using one element for each component. If the equilibrium equations after the enforcement of boundary conditions are to be written as:

$$[K]\{u\} = \{F\}$$

determine the stiffness matrix $[K]$ and the load vector $\{F\}$.